

Manual for The Original C Plus System



“We believe in freedom of culture. Our aim with this furniture is to show that no ideas should be stagnated and no rules should prevent others from learning and developing their own ideas.”
TotemCollective



Attribution-Noncommercial-Share Alike 2.5 Denmark

For further information please visit:

<http://creativecommons.org/licenses/by-nc-sa/2.5/dk/deed.en>

TOCPS Grid: 412,5 mm x 412,5 mm / 16.24" x 16.24"

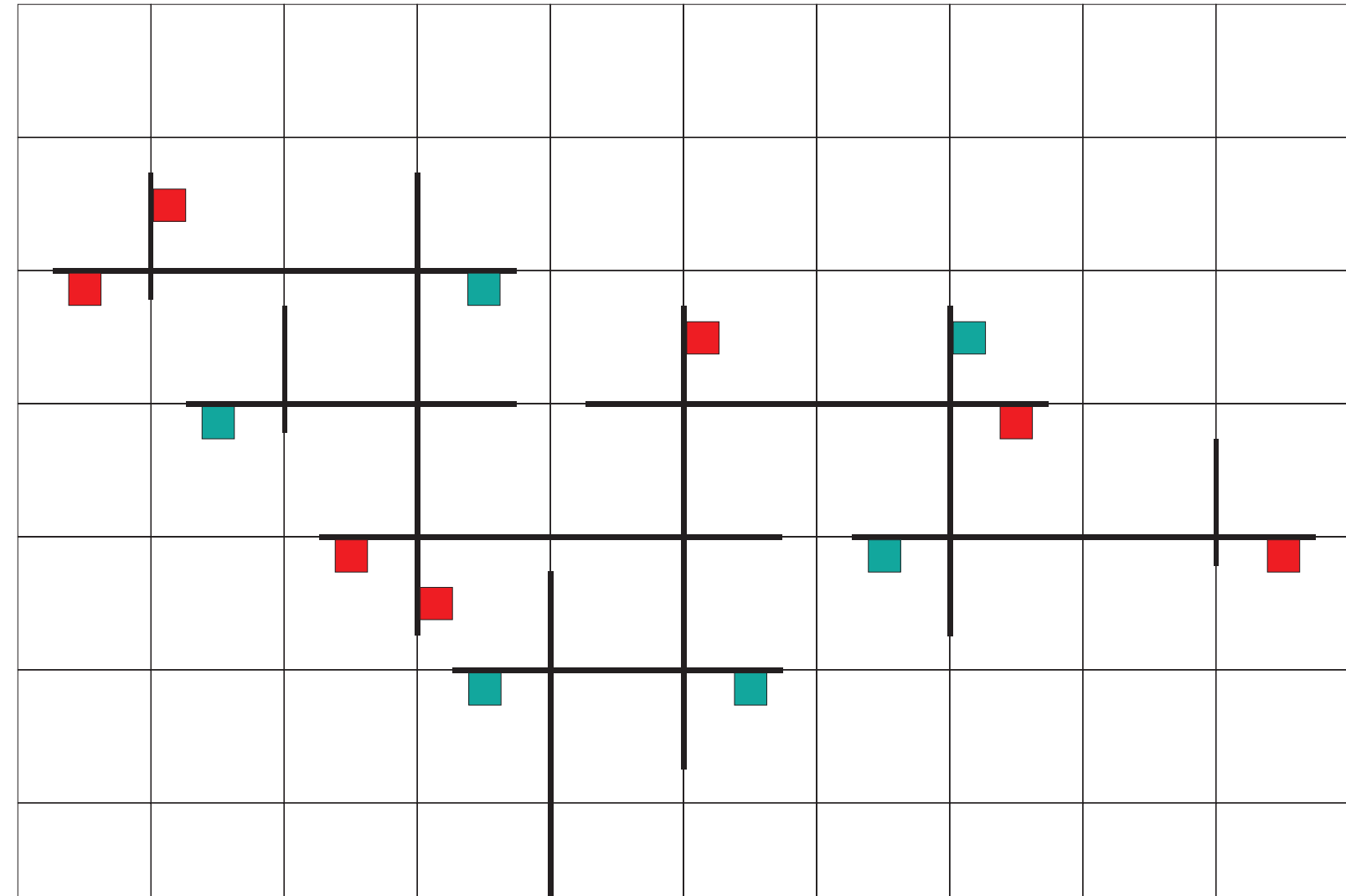

Fixing TOCPS on the wall

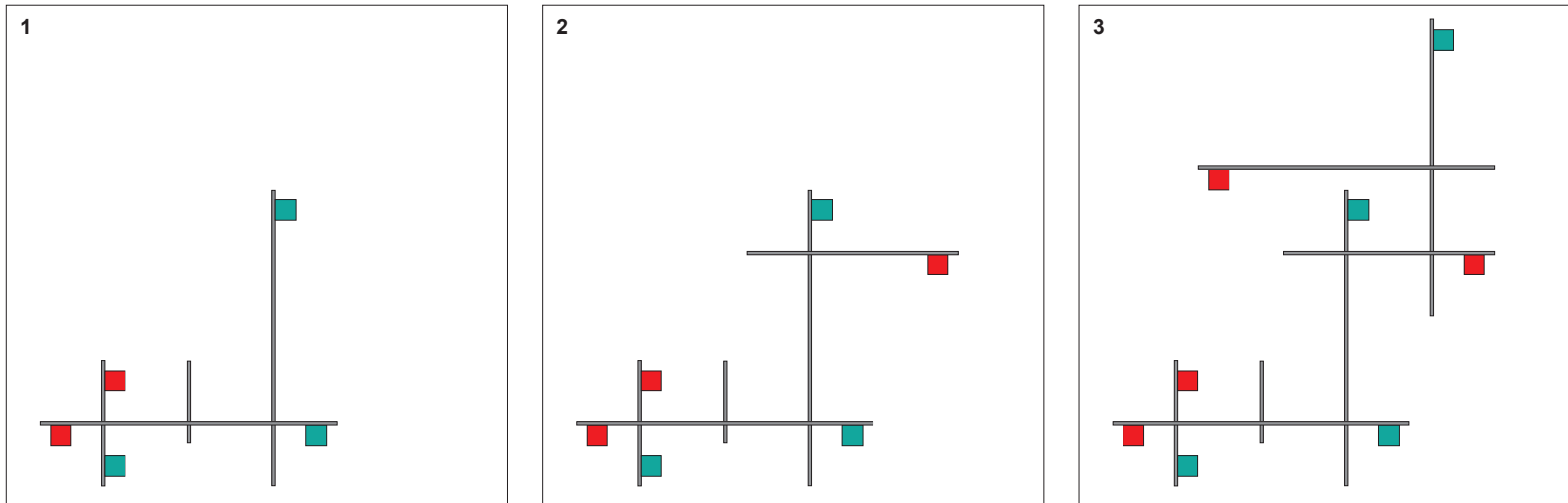

TOCPS is fixed to the wall with fixing blocks. The idea is to use a minimum of fixing blocks according to the overall construction. The system is open and the modules and fixing blocks create an overall simple aesthetic of straight lines and colored points.

All spareparts in the fixing system have a function within the construction. The fixing block is drilled onto the wall. The outer block is then slid onto the fixing block and adjusted to the shelf.



Colours



Rape Yellow RAL 1021



Dafodil Yellow RAL 1007



Coralred RAL 30161



May Green RAL 6017



Turquoise Blue RAL 5018



Black Grey RAL 7021



White

Overview of TOCPS elements

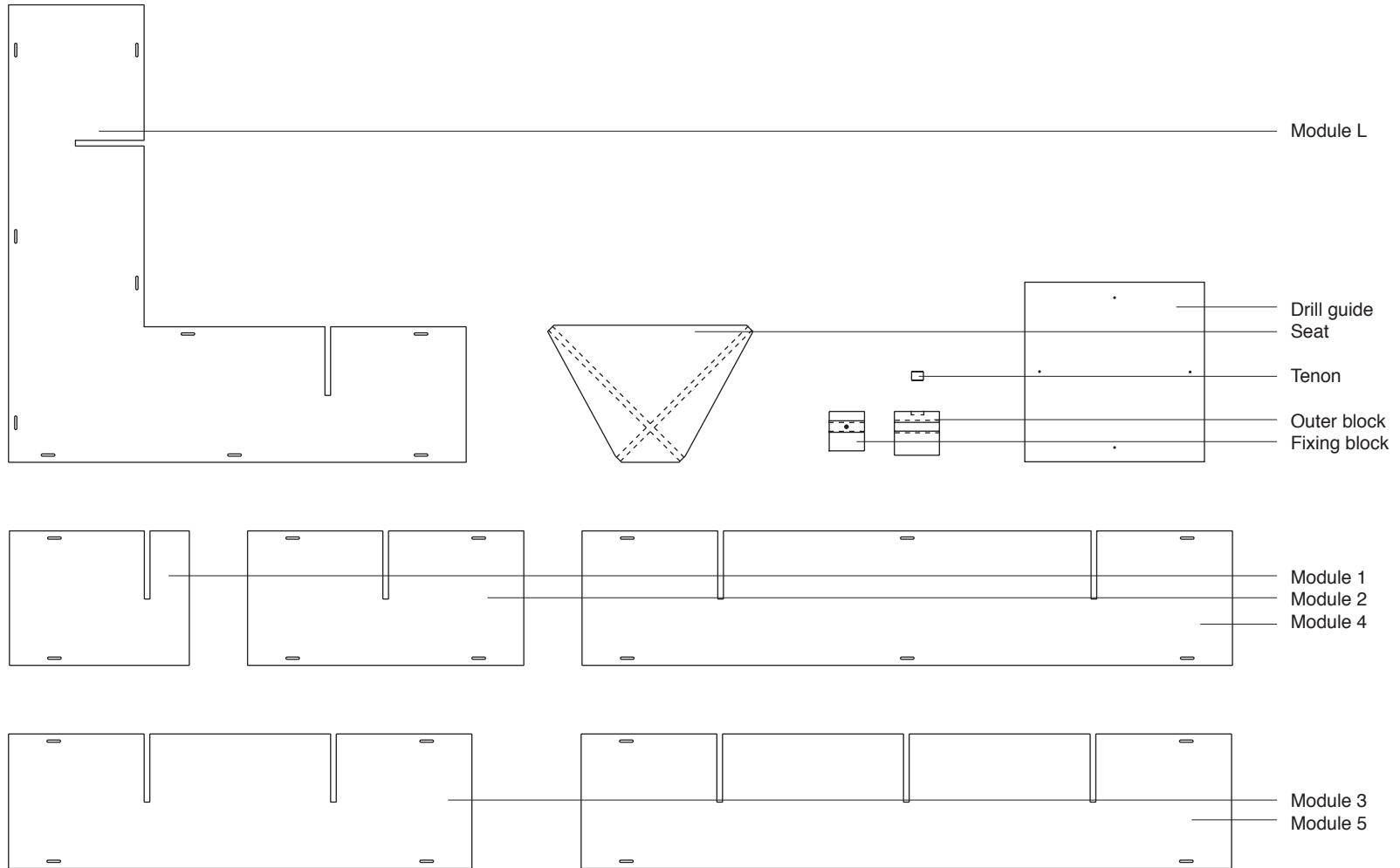

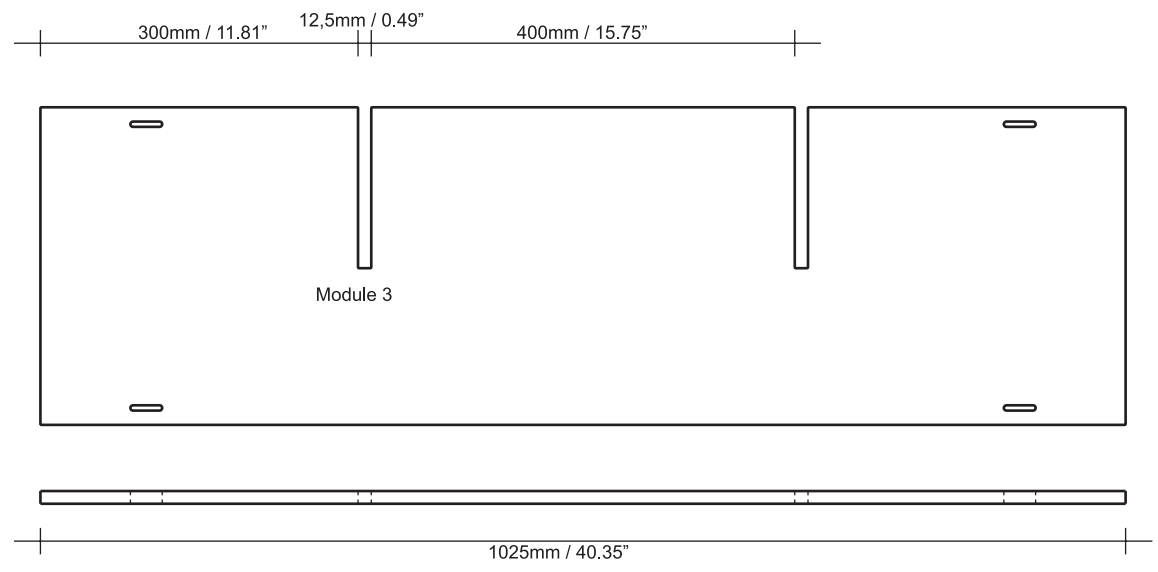
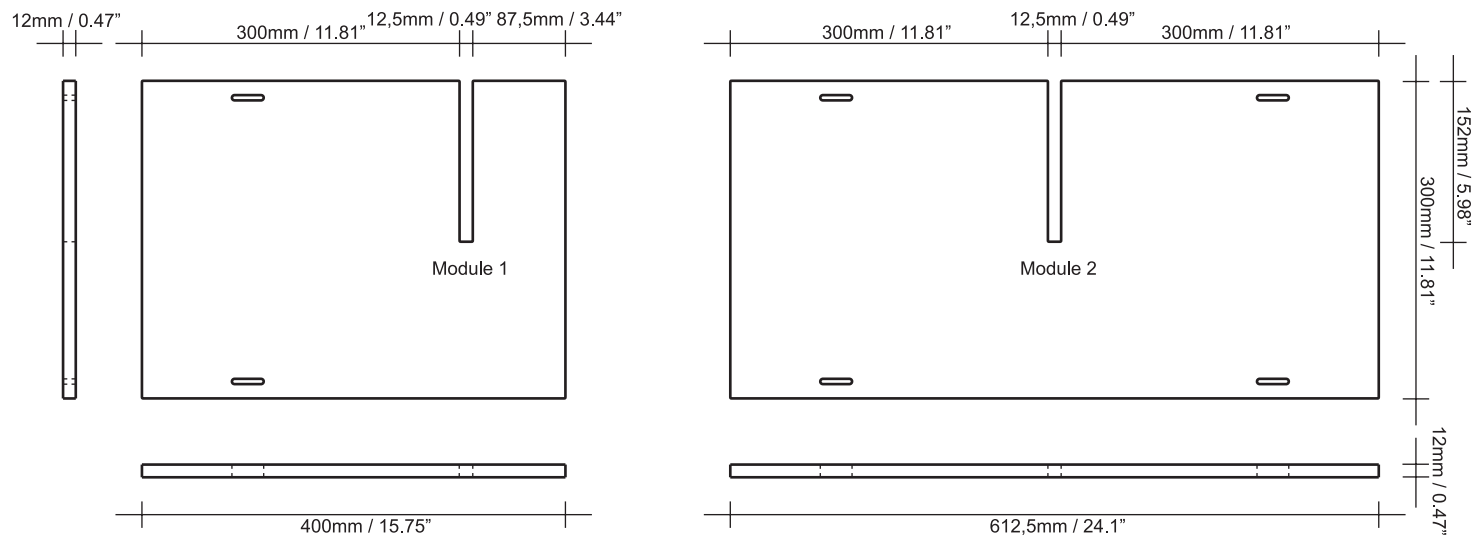

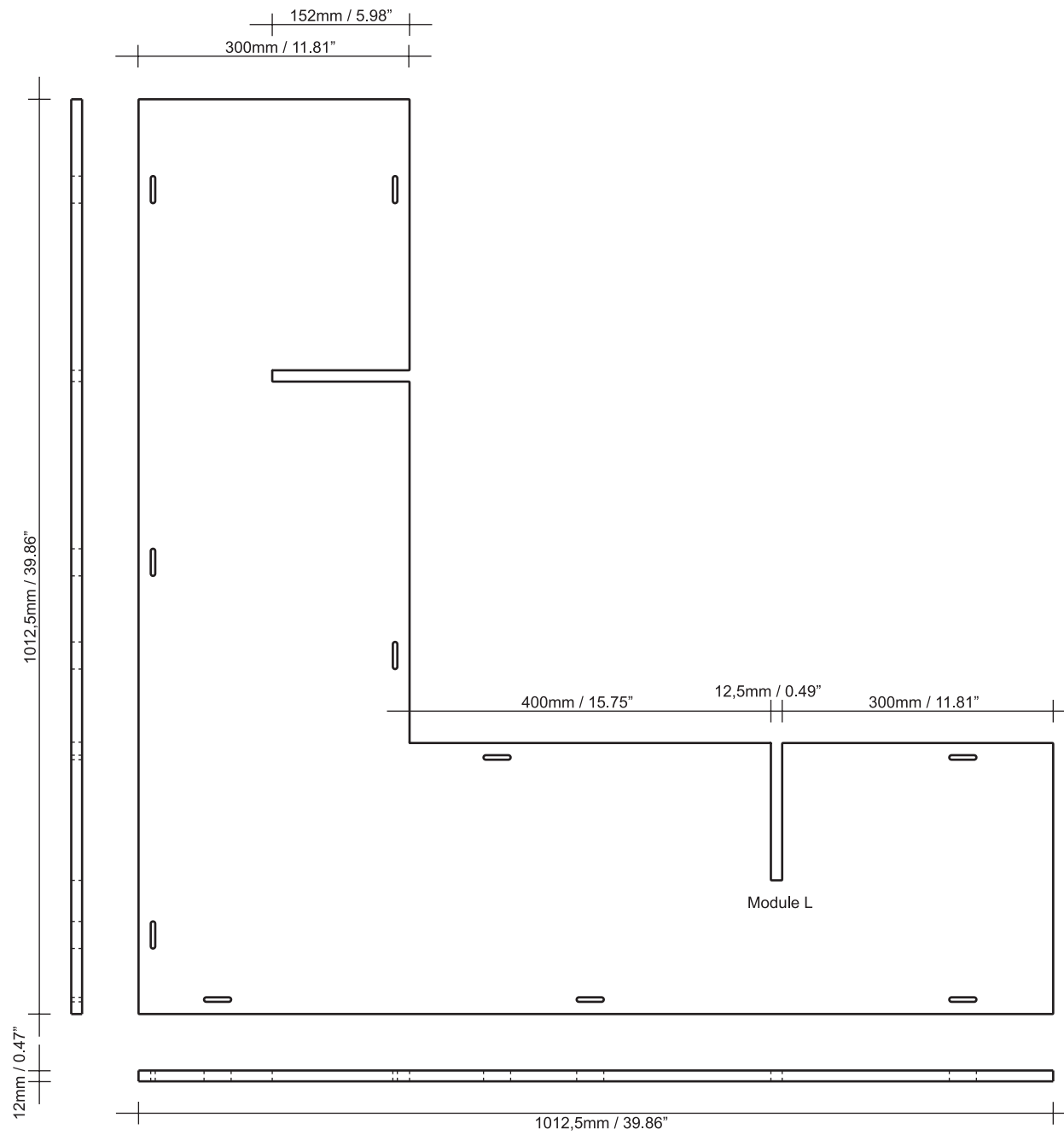

THE ORIGINAL C PLUS SYSTEM

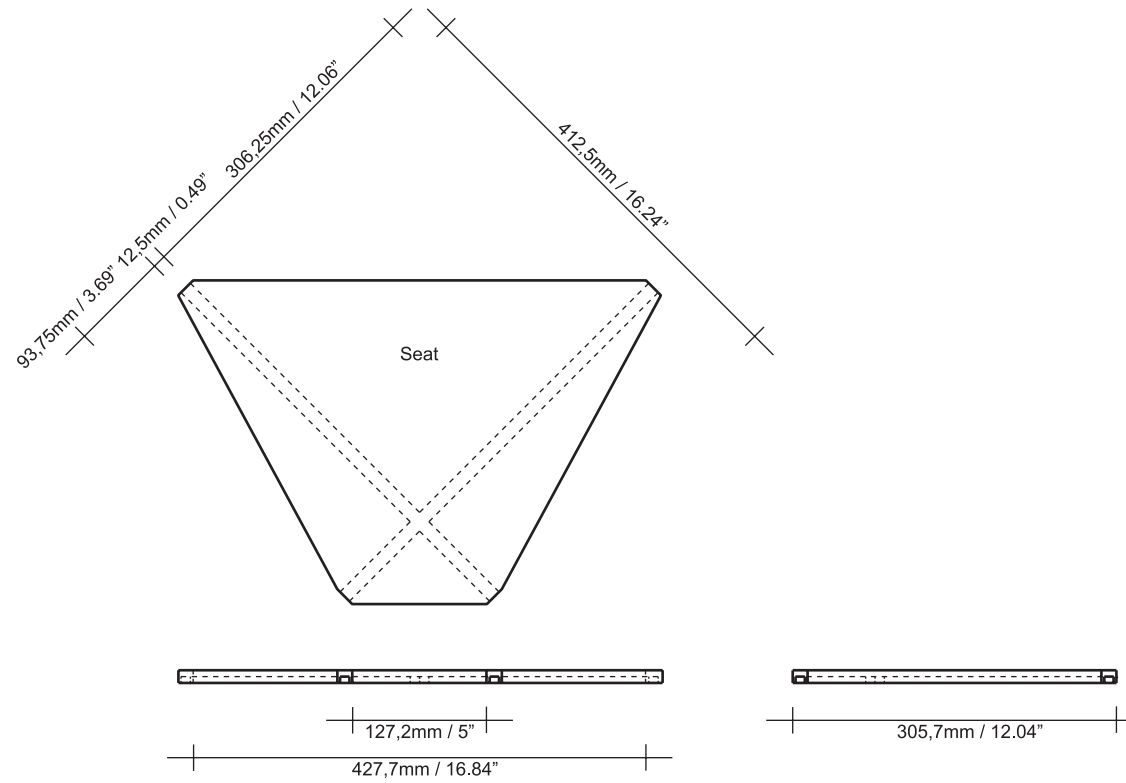

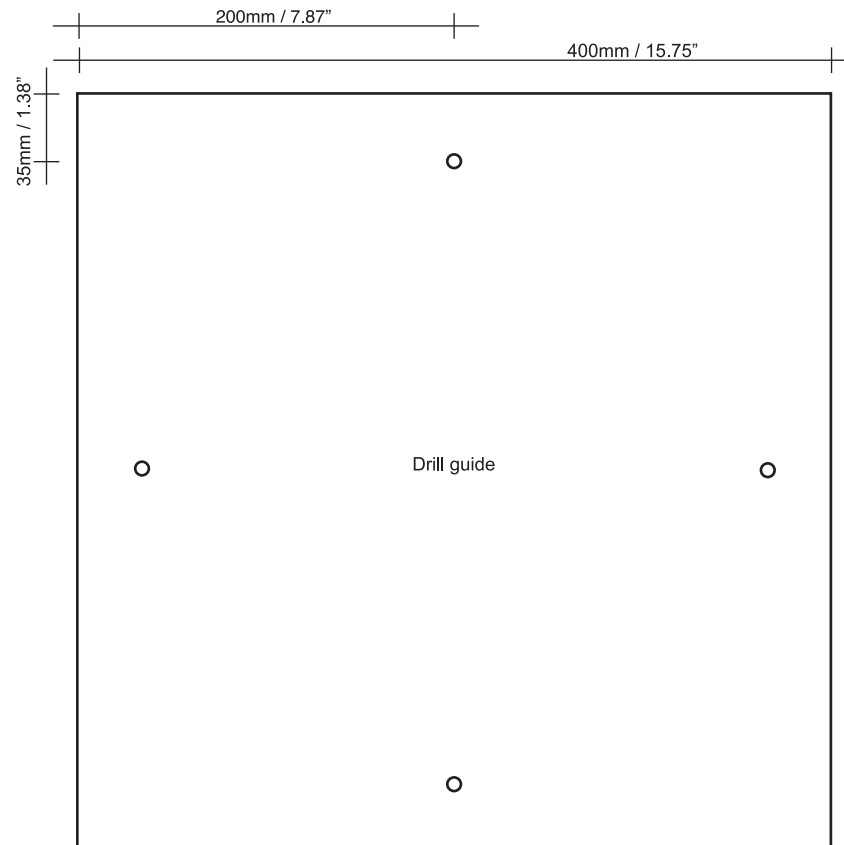

Thanks to

Superflex

Copenhagen Brains

Jørgen Christensen Snedkeri

Kvadrat

Chris Molinski, Curator, The Art Gallery of Knoxville

Leslie Starrit, Law student, The University of Tennessee

Jason S. Brown, Associate Professor of Art, Sculpture program, The University of Tennessee

Gregor Kalas, Assistant Professor, School of Architecture, The University of Tennessee

Eric Ohlgren, Heuristic Workshop, Knoxville

Students from the school of architecture, 2008, The University of Tennessee

Students from the sculpture program, 2008, The University of Tennessee



TotemCollective
Sankelmarksgade 11, st tv
1676 Copenhagen V
Denmark

e: info@totemcollective.com
w: www.totemcollective.com